

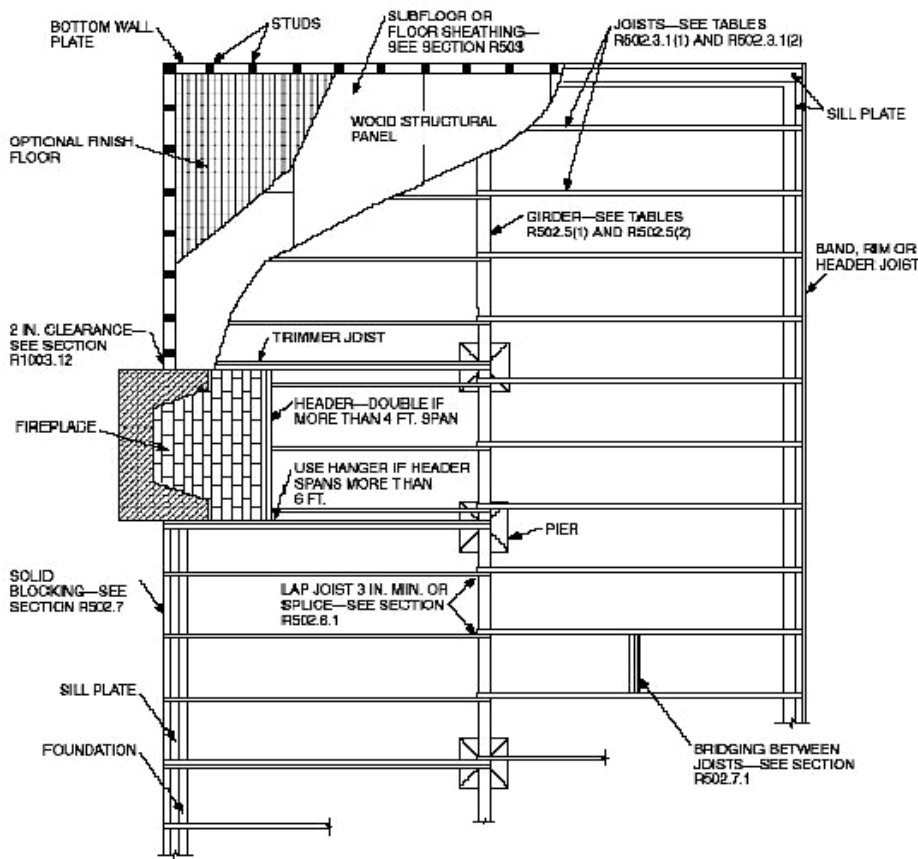

FLOOR FRAMING DETAILS

PLEASE INDICATE IN THE SPACES PROVIDED AT THE BOTTOM OF THIS PAGE, THE PROPOSED SIZE(S) AND SPACING/LENGTH OF FLOOR FRAMING:

NOTE: These drawings are not meant to serve as a substitute for standard construction plans and drawings where required. The illustrations shown are provided to assist customers or homeowners who possess limited construction knowledge.



FLOOR JOIST SIZE = _____ IN. X _____ IN. @ _____ INCHES O.C.

BEAM/GIRDER SIZE = _____ EA. _____ IN. X _____ IN. @ _____ FT

**FIGURE R602.2
 FLOOR CONSTRUCTION**

FOUNDATION AND FOOTING DETAILS

PLEASE CIRCLE THE TYPE OF FOUNDATION YOU ARE PROPOSING AND INDICATE IN THE SPACES PROVIDED, THE WIDTH AND DEPTH OF PROPOSED FOOTINGS

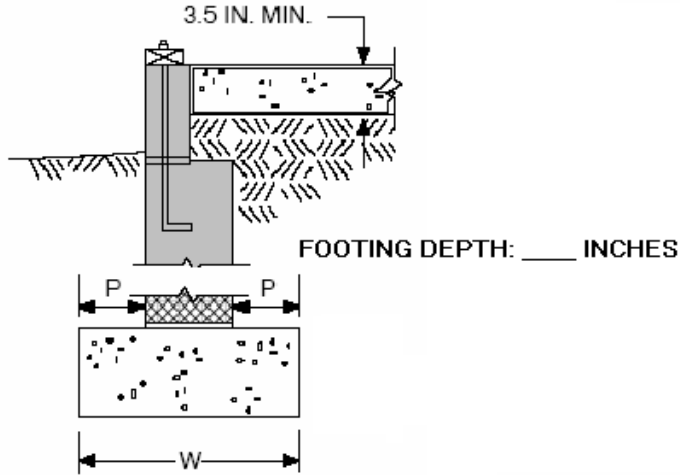

FOOTING WIDTH: ____ INCHES

GROUND SUPPORT SLAB
WITH MASONRY WALL
AND SPREAD FOOTING

INTERIOR PIER

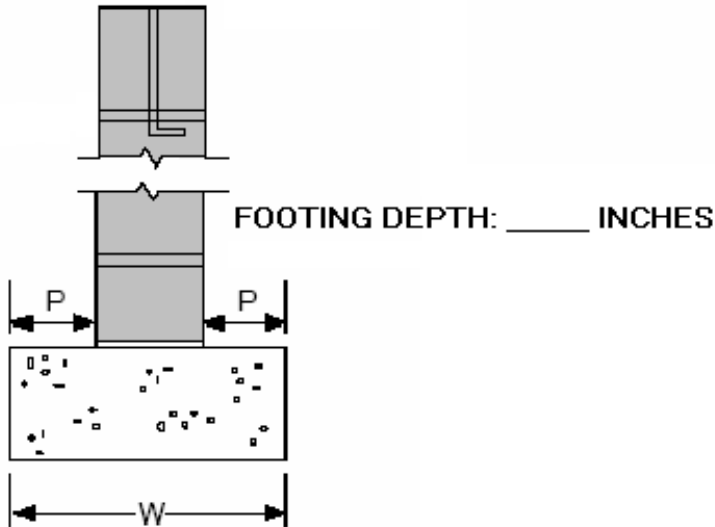

FOOTING WIDTH: ____ INCHES

BASEMENT OR CRAWL SPACE
WITH MASONRY WALL AND
SPREAD FOOTING

NOTE: These drawings are not meant to serve as a substitute for standard construction plans and drawings where required. The illustrations shown are provided to assist customers or homeowners who possess limited construction knowledge.

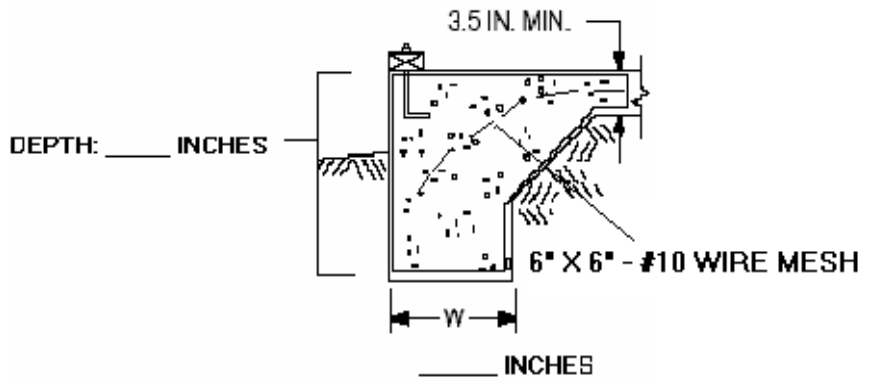

MONOLITHIC SLAB

NOTICE: The International Residential Code requires that footings of foundations shall be placed at least 12 inches below undisturbed ground or if placed on fill, soils must be capable of supporting the footings and foundation and shall be designed, installed and tested in accordance with accepted engineering practice.

ROOF AND WALL FRAMING DETAILS

PLEASE ENTER THE SIZE OF PROPOSED RAFTERS, CEILING JOISTS, STUDS, AND HEADERS IN THE BLANK SPACES PROVIDED BELOW:

NOTE: These drawings are not meant to serve as a substitute for standard construction plans and drawings where required. The illustrations shown are provided to assist customers or homeowners who possess limited construction knowledge.

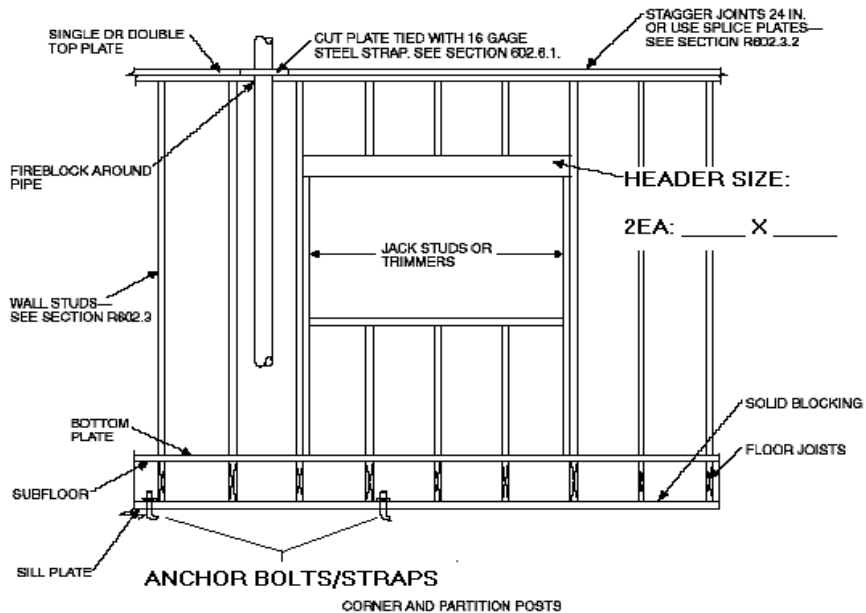
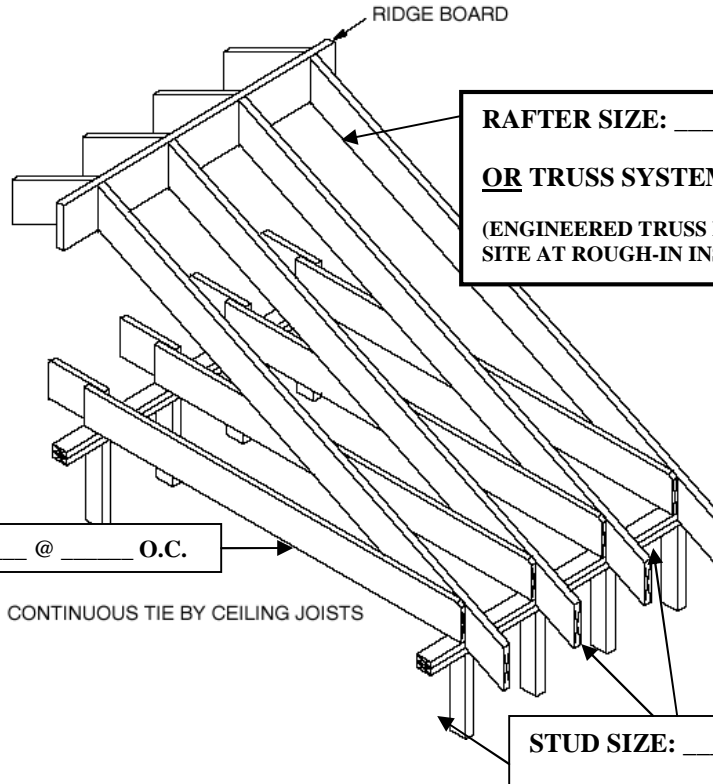

Note: A third stud and/or partition intersection backing studs shall be permitted to be omitted through the use of wood backing cleats, metal drywall clips or other approved devices that will serve as adequate backing for the facing materials.

SAMPLE SITE PLAN

Please identify lot lines, driveways, other structures, underground storage tanks, septic tanks, electrical cables, gas piping, etc

